

CE 213A

Introduction to Environmental Science

<h2><i>L 7 : Module A</i></h2> <h2>Conventional Energy Sources</h2>

Dr. Anubha Goel

FB 308, anubha@iitk.ac.in, x 7027

Schedule : LEC: Tt. Thu 5:10 - 6:30; T108

Energy Sources

- **Primary Energy sources-**
 - Fossil fuels (oil, natural gas, coal)
 - Nuclear energy
 - Falling water, geothermal, solar
- **Secondary Energy sources-**
 - Sources derived from a primary source like...
 - Electricity
 - Gasoline
 - Alcohol fuels (gasohol)

TYPES OF FOSSIL FUELS

1. Liquid Hydrocarbons- Petroleum (oil)
2. Coal
3. Natural Gas



Photo credit: California Energy Commission



CE213A - L7



Problems with Fossil Fuels



- Non-renewable
 - At projected consumption rates, natural gas & petroleum will be depleted by the end of the 21st century
- Impurities are major source of pollution
 - **SO₂** travels on air currents & falls with precipitation as **acid rain**
 - **Mercury bio-accumulates & biomagnifies** thru ecosystems when it travels on air currents and fall as **particulate dust or with precipitation** elsewhere.
- Burning fossil fuels produces large amounts of CO₂, which contributes to **global warming**
- Makes us rely on other countries for our energy needs. Makes us vulnerable.

1. OIL

- Liquid mixture of hydrocarbons with S, O, N impurities
 - Impurities can create SO_2 and NO_x air pollution
- Formed from remains of plankton, plants, animals in shallow seas millions of years ago.
- May be pumped up or may be under pressure
- Important producers: OPEC, Alaska, Siberia, Mexico



Advantages

**Ample supply for
35–84 years**

**Low cost (with
huge subsidies)**

**High net
energy yield**

**Easily transported
within and
between countries**

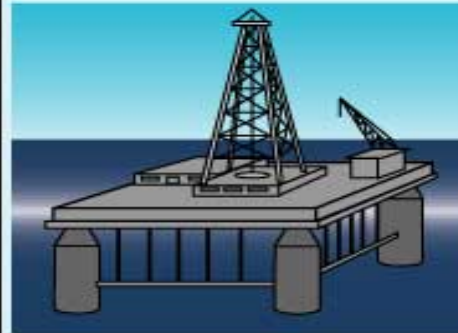
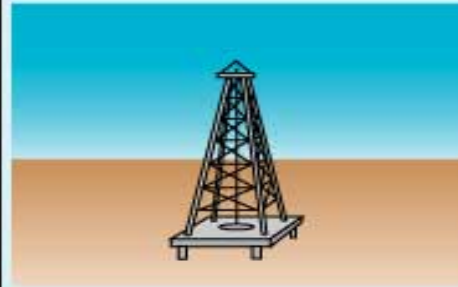

Disadvantages

**Need to find
substitute within
50 years**

**Artificially low
price encourages
waste and
discourages
search for
alternatives**

**Air pollution
when burned**

**Releases CO₂
when burned**

**Moderate water
pollution**

2. NATURAL GAS

- Mixture
 - 50–90% Methane (CH_4)
 - Ethane (C_2H_6)
 - Propane (C_3H_8)
 - Butane (C_4H_{10})
 - Hydrogen sulfide (H_2S)



Advantages

**Ample supplies
(125–200 years)**

**High net energy
yield**

**Low cost (with
huge subsidies)**

**Less air pollution
than other
fossil fuels**

**Lower CO₂
emissions than
other fossil fuels**

**Moderate environ-
mental impact**

**Easily transported
by pipeline**

**Good fuel for
fuel cells and
gas turbines**

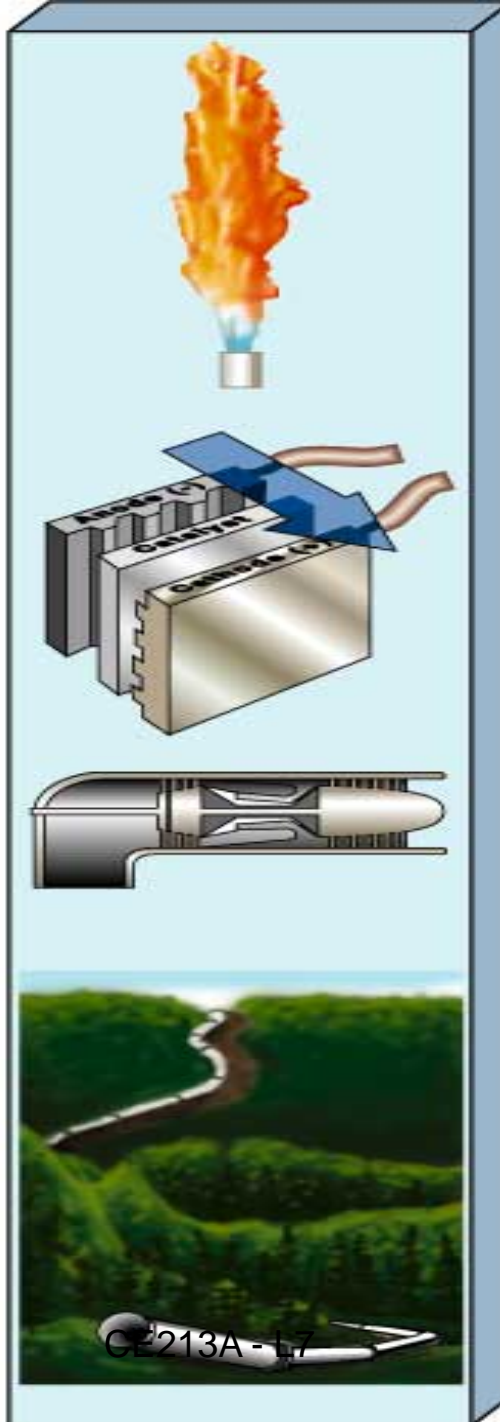

Disadvantages

**Releases CO₂
when burned**

**Leaks of methane
(a greenhouse
gas)**

**Shipped across
ocean as highly
explosive LNG**

**Sometimes
burned off and
wasted at wells
because of low
price**

Natural Gas

- Experts predict increased use of natural gas during this century

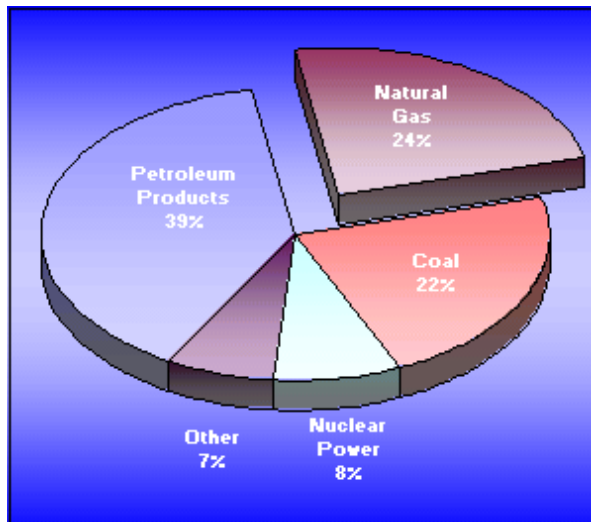
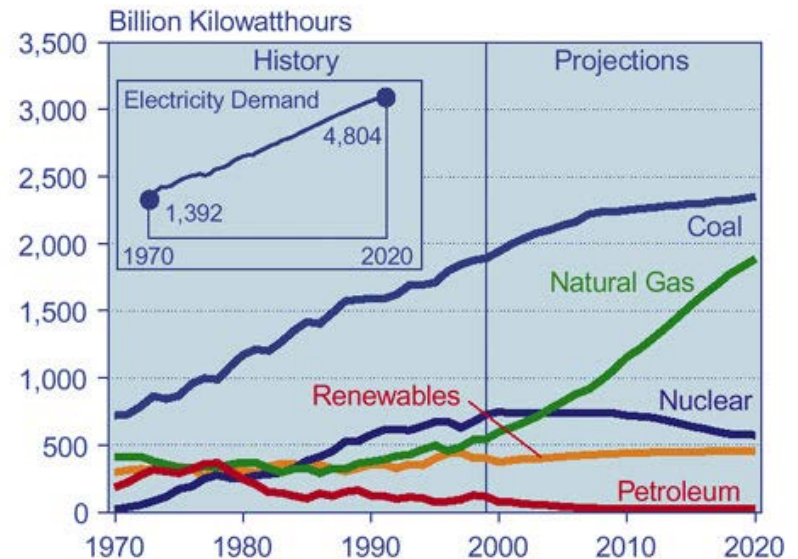

Figure 26. Electricity Generation by Fuel, 1970-2020



Sources: **History:** Energy Information Administration (EIA), Form EIA-860B, "Annual Electric Generator Report - Nonutility;" EIA, *Annual Energy Review 1999*, DOE/EIA-0384(99) (Washington, DC, July 2000); and Edison Electric Institute. **Projections:** EIA, *Annual Energy Outlook 2001*.

3. Coal

- Coal exists in many forms therefore a chemical formula cannot be written for it.
- Coalification: After plants died they underwent chemical decay to form a product known as peat
 - Over many years, thick peat layers formed.
 - Peat is converted to coal by geological events such as land subsidence which subject the peat to great pressures and temperatures.

Advantages and Disadvantages

Pros

- Most abundant fossil fuel
- 300 yrs. at current consumption rates
- High net energy yield

Cons

- Dirtiest fuel, highest carbon dioxide
- Major environmental degradation
- Major threat to health

Alternate Uses of Coal

- Coal **gasification** ®
Synthetic natural gas (SNG) or Syngas (made up of CO and H₂)
- Coal **liquefaction** ®
Liquid fuels (oil) ®
gasoline
- Disadvantage
 - Costly
 - High environmental impact

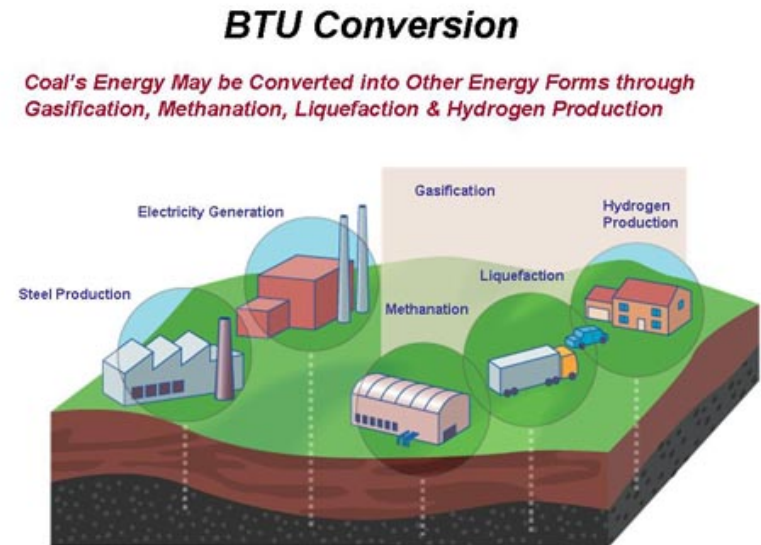

Sulfur in Coal

- When coal is burned, sulfur is released primarily as sulfur dioxide (SO_2 - serious pollutant)
 - Coal Cleaning - Methods of removing sulfur from coal include cleaning, solvent refining, gasification, and liquefaction
 - Two chief forms of sulfur
 - inorganic (FeS_2 or CaSO_4)
 - organic (Sulfur bound to Carbon)

Effects on Ecosystems of acid rain from sulfur dioxide.

- Acid rain leaches metals (Al) out of soil, settles on fish gills, causing suffocation.
- Leaches out soil nutrients
- Kills eggs, larvae, fry (baby fish), and some adult fish
- Changes in pH can make some chemicals more toxic- kills trees or aquatic life
- Decreases health of plants- more susceptible to disease
- As animals die from pH changes, other more hardy animals will fill those new niches
- Upsets food web when sensitive species die.
- If regional climate changes due to cooling from sulfur pollution
 - Changes in crops
 - Changes in vegetation which leads to changes in fauna distribution
 - Changes in precipitation patterns

Resources

- International Energy Agency
 - www.eia.gov
- [Ministry of Power](#)
- [Ministry of New and Renewable Energy](#)
 - www.mnre.gov.in/

The *Ministry* of New and Renewable *Energy* (MNRE) is the nodal *Ministry* of the Government of *India* for all matters relating to new and renewable *energy*.

- [Solar Energy Corporation of India Limited\(SECI\), A ...](#)
 - www.seci.gov.in/