

ME 251 END SEMESTER EXAMINATION

Instructor and Tutors: Anupam Saxena, P. Venkitanarayanan, Ashish Dutta

Date: 29th November, 2018

Max. Marks: 30

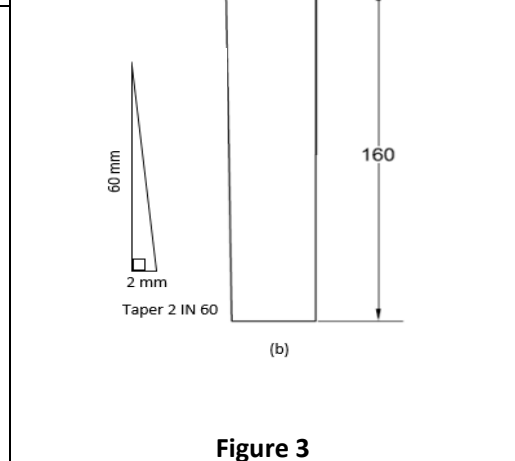
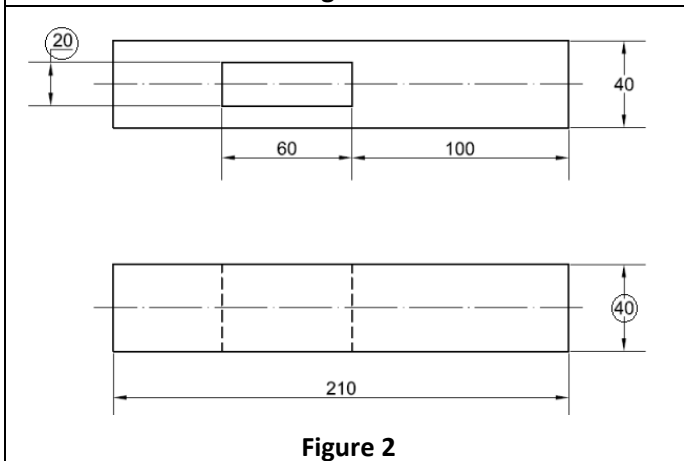
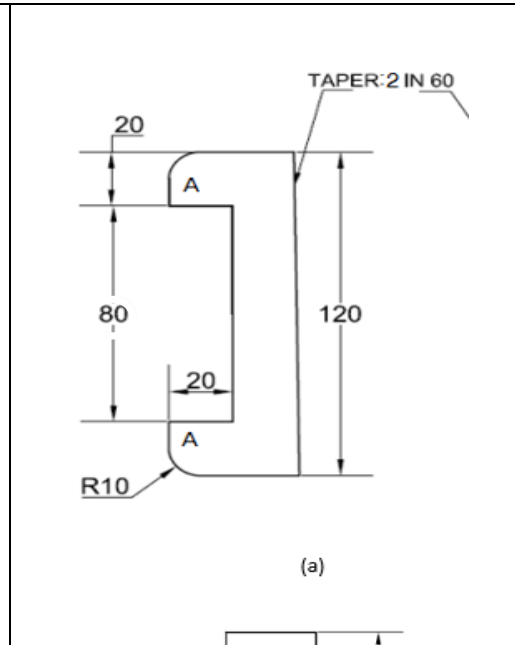
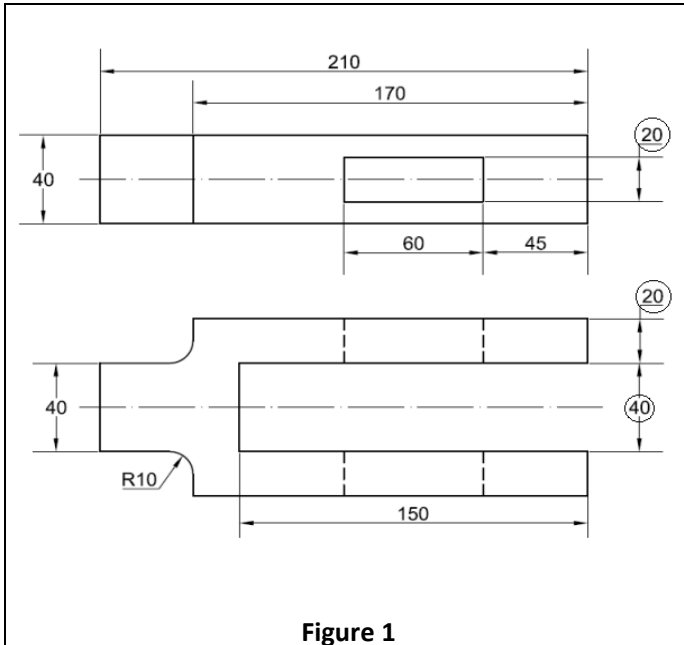

Q1. A rod of square cross section (Figure 2) is to be connected to another rod of square cross section (Figure 1). The rod shown in Figure 1 has a forked end. Each rod has a slot of rectangular shape (60 mm long and 20 mm wide). The rod shown in Figure 2 is placed inside the fork end of rod shown in Figure 1 such that the left end of rod shown in Figure 2 touches the inner surface of the forked end. Then the gib shown in Figure 3(a) is inserted through the slot with its flange (marked A in Figure 3a) facing the open end of the fork. The assembly is fastened together by inserting the cotter shown in Figure 3(b) through the slot.

After assembly, the width of the gib at the center line is 25 mm and that of the cotter is 30 mm. Thickness of both the gib and cotter is 20 mm. All dimensions are in millimeters and third angle projection is used whenever two views are given. The base line dimensions are shown in all Figures.

Draw the **sectioned front view** and **top view (3rd angle projection)** of the assembly in **scale 1:1**. Indicate the dimensions which are circled in the Figures. Also, dimension the overall length of the assembly. Please note while sectioning the gib and cotter are generally not hatched. (15)

PLEASE TURN OVER

Q2.

A spur gear is mounted on a stepped shaft through a key as shown in Figure 4. The shaft is mounted on two roller bearings at the two ends. Dimensions of the shaft are as given in the table below: (15)

	Point 'A'	Point 'B'	Point 'C'
Length of stepped shaft	50	100	10
Diameter of stepped shaft	80	100	110

The manufacturer has specified the fit on the bearing and shaft at point 'A' as **H7p6** and the fit between the shaft and gear at point 'B' as **H7k6**. Find the working dimensions of:

- a) The stepped shaft at point 'A' where the bearing is mounted.
- b) The shaft at point 'B' where the gear is mounted.
- c) Calculate the maximum and minimum clearance/interference at points 'A' and 'B'.
- d) It is required that the shaft has a circularity tolerance of 0.05 mm.

Draw the stepped shaft and indicate dimensions with tolerances you have calculated above (ignore the keyway in the shaft).

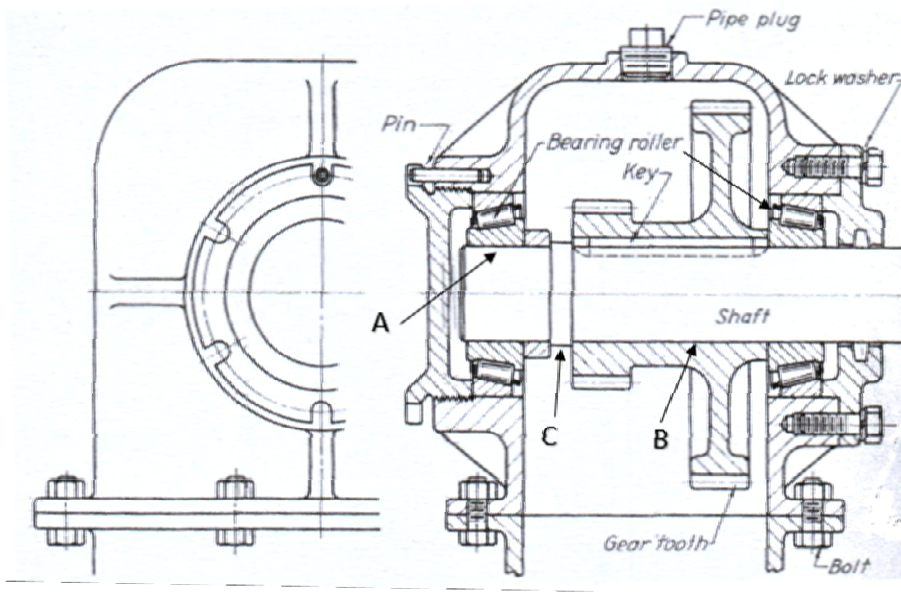

Figure 4