

AE-231

ELEMENTS OF VIBRATIONS

①

A car is descending the hill of slope θ_1 with the brakes slightly applied so that the speed v is constant. The slope decreases abruptly to θ_2 at point A. If the driver does not change the braking force, determine the acceleration a of the car after it passes point A. Evaluate your expression for $\theta_1 = 6^\circ$ and $\theta_2 = 2^\circ$.

Ans. $a = g(\sin \theta_2 - \sin \theta_1)$, $a = -0.0696g$

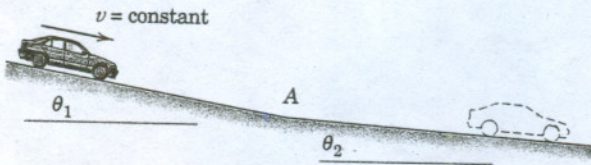

④

In the design of a conveyor-belt system, small metal blocks are discharged with a velocity of 0.4 m/s onto a ramp by the upper conveyor belt shown. If the kinetic coefficient of friction between the blocks and the ramp is 0.30, calculate the angle θ which the ramp must make with the horizontal so that the blocks will transfer without slipping to the lower conveyor belt moving at the speed of 0.14 m/s.

Ans. $\theta = 16.62^\circ$

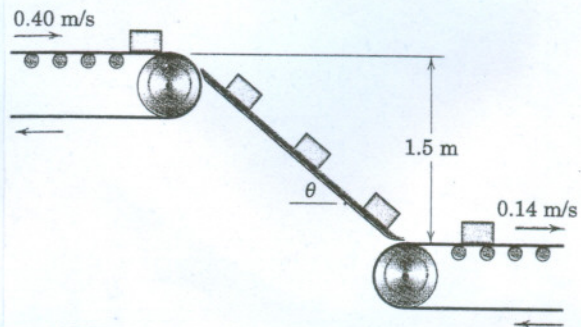

②

The slotted arm revolves in the horizontal plane about the fixed vertical axis through point O. The 2-kg slider C is drawn toward O at the constant rate of 50 mm/s by pulling the cord S. At the instant for which $r = 225$ mm, the arm has a counterclockwise angular velocity $\omega = 6$ rad/s and is slowing down at the rate of 2 rad/s². For this instant, determine the tension T in the cord and the magnitude N of the force exerted on the slider by the sides of the smooth radial slot. Indicate which side, A or B, of the slot contacts the slider.

Ans. $T = 16.20$ N, $N = 2.10$ N, side B

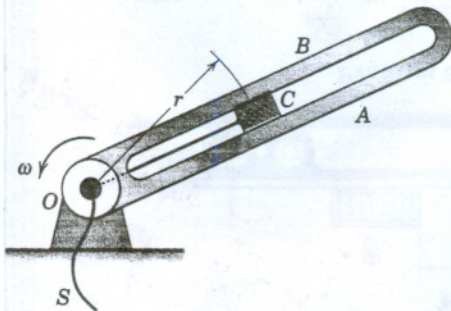

⑤

The 0.60-kg collar slides on the curved rod in the vertical plane with negligible friction under the action of a constant force F in the cord guided by the small pulleys at D. If the collar is released from rest at A, determine the force F which will result in the collar striking the stop at B with a velocity of 4 m/s.

Ans. $F = 13.21$ N

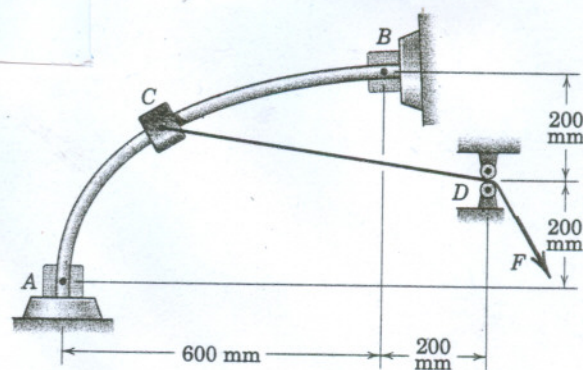

③

The 6-kg cylindrical collar is released from rest in the position shown and drops onto the spring. Calculate the velocity v of the cylinder when the spring has been compressed 50 mm.

Ans. $v = 2.41$ m/s

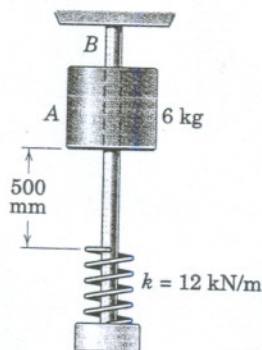

- 6 The system is released from rest with the spring initially stretched 75 mm. Calculate the velocity v of the cylinder after it has dropped 12 mm. The spring has a stiffness of 1050 N/m. Neglect the mass of the small pulley.

Ans. $v = 0.371$ m/s

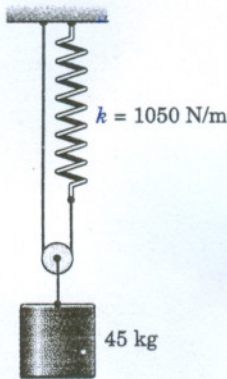

- 7 The 900-kg motorized unit A is designed to raise and lower the 600-kg bucket B of concrete. Determine the average force R which supports unit A during the 6 seconds required to slow the descent of the bucket from 3 m/s to 0.5 m/s. Analyze the entire system as a unit without finding the tension in the cable.

Ans. $R = 14.96$ kN

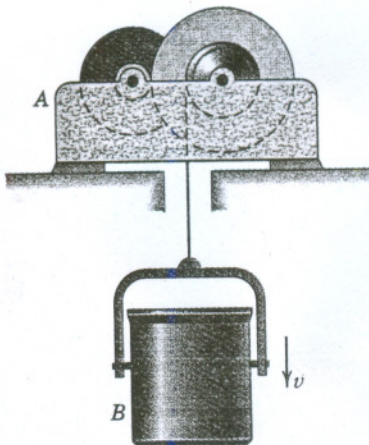

- 8 The two springs, each of stiffness $k = 1.2$ kN/m, are of equal length and undeformed when $\theta = 0$. If the mechanism is released from rest in the position $\theta = 20^\circ$, determine its angular velocity $\dot{\theta}$ when $\theta = 0$. The mass m of each sphere is 3 kg. Treat the spheres as particles and neglect the masses of the light rods and springs.

Ans. $\dot{\theta} = 4.22$ rad/s

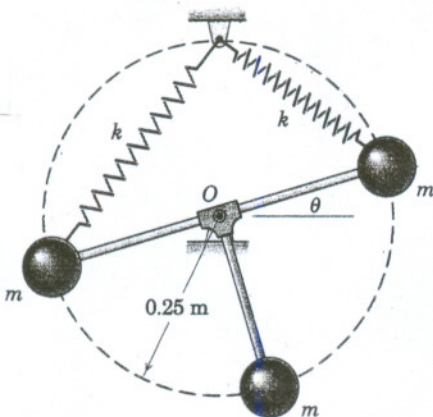

- 9 Each of the four spheres of mass m is treated as a particle. Spheres A and B are mounted on a light rod and are rotating initially with an angular velocity ω_0 about a vertical axis through O. Spheres C and D are also mounted on a light rod which is pivoted independently about O and is initially at rest. Assembly AB contacts CD where slots in A and B allow engagement and latching to CD in the dashed position shown. Both units then rotate with a common angular velocity ω . Frictional resistance is negligible. Determine expressions for ω and the percentage loss n of kinetic energy.

Ans. $\omega = \omega_0/5, n = 80\%$

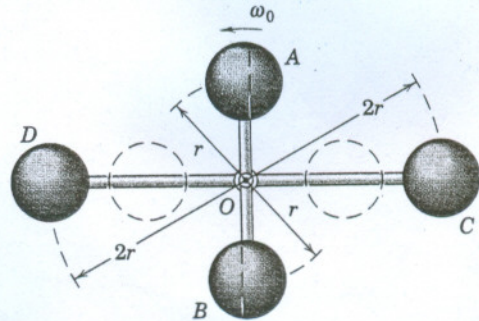

- 10 When $\theta = 90^\circ$, the spring of stiffness $k = 2$ kN/m is uncompressed. If the balls are released from rest in their top position, calculate their velocity v as they strike the horizontal surface with $\theta = 0$. Treat each ball as a particle and neglect the mass of the right-angled members and any friction.

Ans. $v = 1.368$ m/s

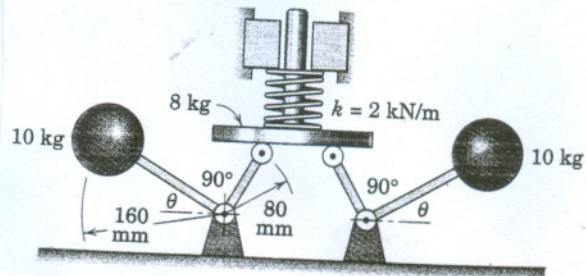

- 11 The ball A of mass 10 kg is attached to the light rod of length $l = 0.8$ m. The mass of the carriage alone is 250 kg and it moves with an acceleration a_O as shown. If $\dot{\theta} = 3$ rad/s when $\theta = 90^\circ$, find the kinetic energy T of the system if the carriage has a velocity of 0.8 m/s (a) in the direction of a_O and (b) in the direction opposite to a_O . Treat the ball as a particle.

Ans. (a) $T = 112$ J, (b) $T = 112$ J

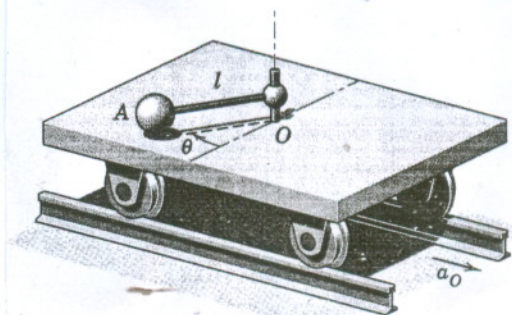

12

Each of the identical 4-kg steel balls is fastened to the other two by connecting bars of negligible mass and unequal length. In the absence of friction at the supporting horizontal surface, determine the initial acceleration \bar{a} of the mass center of the assembly when it is subjected to the horizontal force $F = 200 \text{ N}$ applied to the supporting ball. The assembly is initially at rest in the vertical plane. Can you show that \bar{a} is initially horizontal?

Ans. $\bar{a} = 16.67 \text{ m/s}^2$

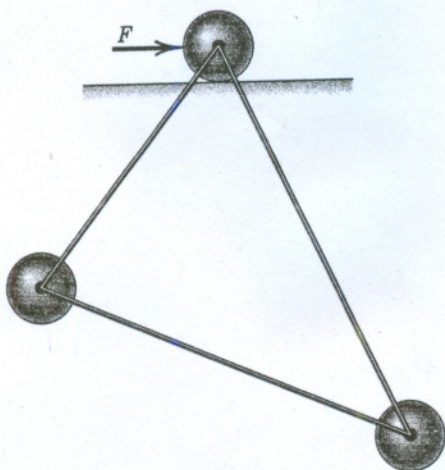

14

The three identical spheres, each of mass m , are supported in the vertical plane on the 30° incline. The spheres are welded to the two connecting rods of negligible mass. The upper rod, also of negligible mass, is pivoted freely to the upper sphere and to the bracket at A. If the stop at B is suddenly removed, determine the velocity v with which the upper sphere hits the incline. (Note that the corresponding velocity of the middle sphere is $v/2$.) Explain the loss of energy which has occurred after all motion has ceased.

Ans. $v = 4.20 \text{ m/s}$

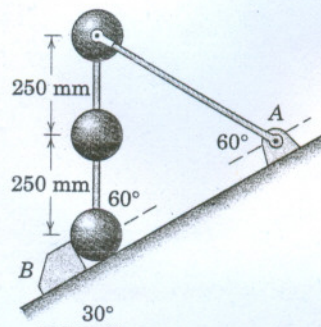

13

A 60-g bullet is fired horizontally with a velocity $v = 300 \text{ m/s}$ into the slender bar of a 1.5-kg pendulum initially at rest. If the bullet embeds itself in the bar, compute the resulting angular velocity of the pendulum immediately after the impact. Treat the sphere as a particle and neglect the mass of the rod. Why is the linear momentum of the system not conserved?

Ans. $\omega = 11.88 \text{ rad/s}$

