

END-TO-END INDIA-UK TRANSNATIONAL WIRELESS TESTBED

Rohit Budhiraja¹, Bhaskar Ramamurthi², Babu Narayanan¹, A. Oredope³

¹Centre of Excellence in Wireless Technology (CEWIT), Chennai, India

Email: {rohit,babunkj}@cewit.org.in

²Department of Electrical Engineering,
Indian Institute of Technology Madras, India

Email: bhaskar@tenet.res.in

³The Centre for Communication Systems Research (CCSR),
University of Surrey, Guildford, United Kingdom

Email: A.Oredope@surrey.ac.uk

Abstract

Wireless Communication is a fast growing technology area where tremendous amount of research is ongoing. It is also an area where the use of technology in the market has seen wide and far-reaching impact. The India-UK Advanced Technology Centre initiative is a collaborative research project between various institutes and companies across UK and India, which envisages, apart from several research outcomes, putting in place of a support infrastructure for facilitating R&D of Next Generation networks, Systems and Services. As part of this project, an end-to-end trans-national advanced wireless testbed is being developed which will facilitate and support research and implementation of new ideas, concepts and technologies. The testbed will provide a framework which can be used to rapidly prototype and evaluate emerging concepts and technologies, and enables researchers to investigate/demonstrate the feasibility of new ideas in a realistic test environment. The testbed complements analytical and simulation based studies undertaken as part of the initial study when new ideas are proposed. This paper gives the details of the testbed and shows how a 4G technology like LTE has been implemented as one of the realisations of the test bed.

Keywords: Testbed, Access-network, Cooperative schemes, centralized processing, distributed processing

1 INTRODUCTION

Emerging broadband wireless standards such as 3GPP LTE and 802.16e/m have been designed to provide DSL-type data rates over wireless. They enable this by using state-of-art communication techniques, by employing multiple antennas at the transmitter/receiver, and by effective usage of spectrum. Communication techniques specified in the standards include among others, Hybrid-ARQ [1], adaptive modulation and coding [2], multiple antennas at the transmitter and receiver to increase link reliability [3] and system throughput [4] and more recently, to mitigate the co-channel interference [5]. In order to aid the user-equipment (UE) and to exploit the randomness in the wireless channel, channel state information (CSI) is required at the base-station (BS) [6]. Research is ongoing on each of these areas to improve the techniques and get the best out of the technology [7], [8].

In addition to the above-mentioned techniques, these standards specify the re-use of the entire available spectrum in each cell. This leads to a significant increase in co-channel interference at the cell-edge. The research into co-channel interference mitigation is of great interest and is currently being studied actively [5]. Co-channel interference

mitigation techniques require co-operation among neighbouring BSs and CSI needs to be shared across the neighbouring BSs. CSI is exchanged using the backhaul network interconnecting the BSs.

System-level studies are required to understand and analyze the trade-offs which these schemes offer to maximise the system capacity. Multi-cell system-simulators [9] are generally used for this. These simulators create the fading and interference profiles seen in typical cellular scenarios by employing predefined channel models and much depends on the choice of models. A testbed which can create fading and interference profiles similar to real-world scenarios can further validate the simulation results and can also provide new insights.

Depending on the research requirement, testbeds can generally be characterised into two types, software-defined and high-performance real-time based. The first type is used to generate the data off-line, transmit over the air and then process the received signal also offline. A common feature of the software-defined testbed is the use of MATLAB or similar environment to process transmit and receive data offline. For example, the Hydra testbed from UT Austin [10] makes use of low cost/complexity hardware such as the Ettus kit [11]. It is clear that this kind of testbed can provide a framework to quickly validate an algorithm. So-called open-loop PHY layer schemes, which do not require real-time exchange of CSI could be evaluated in realistic channel conditions using such a framework. However, closed-loop schemes which require real-time CSI exchange between BS and UE cannot be evaluated. The second type of testbed is more complex and uses DSPs and FPGAs to process data in an embedded fashion. There are many examples of such systems [12]–[15], which often utilise multiple FPGA's and DSP's. For example, the Vienna MIMO testbed [16] supports 4x4 MIMO systems using the 2.45GHz band, and is made using commercial off-the-shelf components. The disadvantage of this type of testbed is that an algorithm will have to be first coded and debugged in the embedded platform to enable the real-time transmission.

As part of the India-UK Advanced Technology Center (IU-ATC) initiative, a trans-national end-to-end testbed framework has been developed with flexibility to support both the types of tests described above, or a convenient combination thereof. The testbed will be used to study the performance of the advanced algorithms being developed by various teams within the project. This end-to-end testbed will have all the components of the next-generation wireless network - Access-network, Core-network and Service-delivery platform. This testbed is built in a collaboration

between IIT Madras (IITM) in India and University of Surrey (UniS) in the UK. Access and Core-network components of the testbed will be located in the IITM campus and the Service Delivery platform will be located in UniS. The testbeds in IITM and UniS will be interconnected using high-speed academic networks - the National Knowledge Network [17] in India and GEANT [18] in Europe.

This paper describes the architecture of the Access-network testbed currently being developed at IITM and CEWiT in collaboration with key industrial partners. The hardware for the access network has been fully designed at IIT Madras. It is architected using software defined radio

(SDR) based radio nodes. The testbed is also exercised using an LTE technology implementation. IITM and CEWiT are developing the baseline LTE PHY for both Base Station (BS) and User Equipment (UE), while MAC and rest of the stacks and the Core-network nodes are being brought in by the industrial partners.

In this paper, we first describe the layout and design of the Access-network testbed, which mimics a typical cellular network. We then provide a detailed description of the software schematics and hardware architecture of the Access-network. A brief overview of the Core-network and Service-delivery platform is also provided in the end.

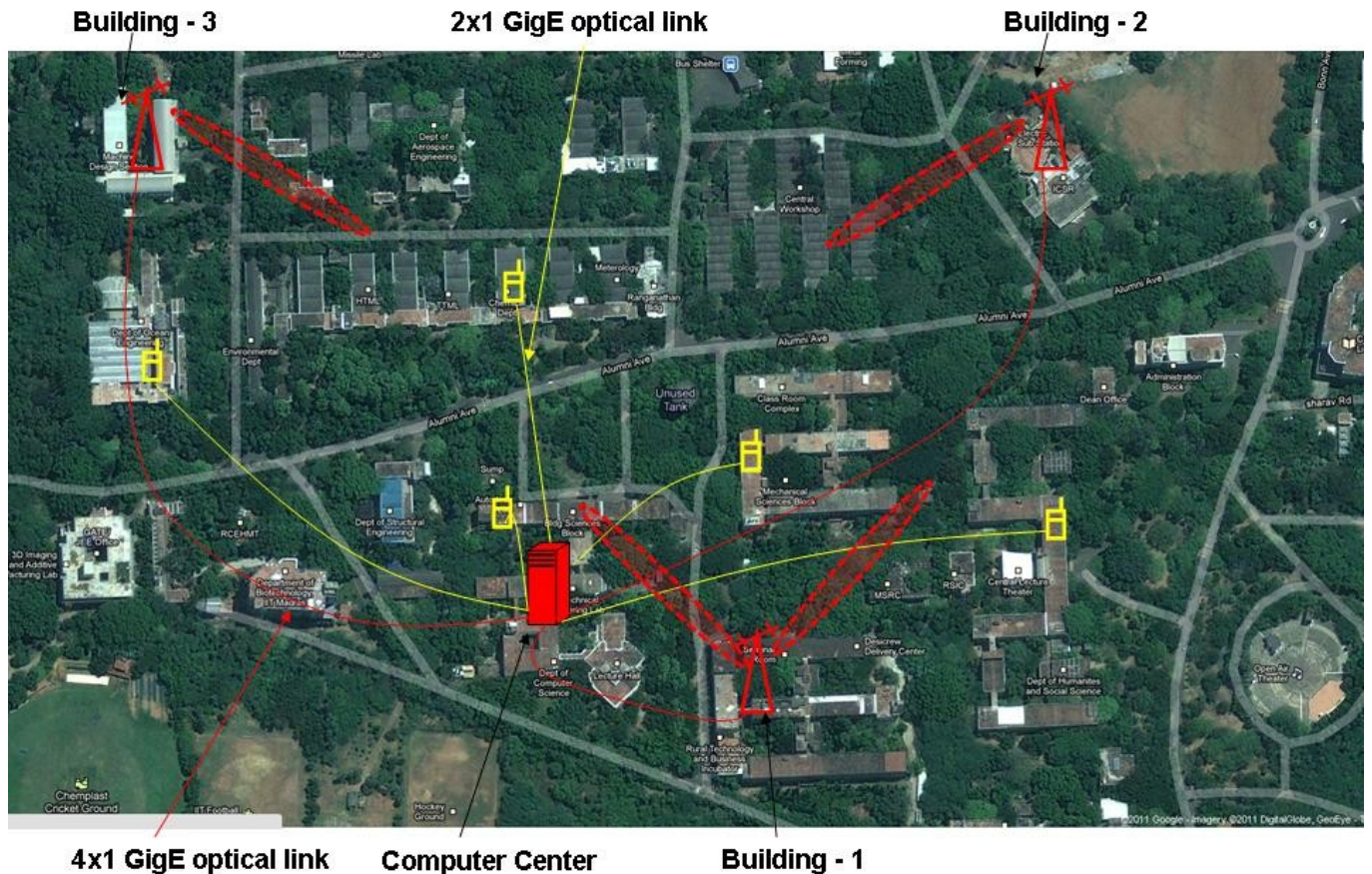

Fig.1. Layout of the IITM Access-network testbed

2 ACCESS-NETWORK TESTBED LAYOUT AND DESIGN

Figure-1 shows the layout of the testbed on a zoomed-in aerial view of the Institute (courtesy – Google Maps). The testbed has four BS nodes (red in color) and ten UE nodes (yellow in color). Four BS nodes are installed on three different buildings with two of them being co-located in Building-1 as adjacent sectors. UE nodes will be deployed uniformly in the coverage area of the BS nodes. The chosen site locations includes various propagation conditions which are of interest for evaluation of next-generation systems with MIMO links and interference conditions typical in frequency reuse-1 systems like LTE. In particular,

- the testbed layout mimics the network layout in a typical Indian city with multi-storey buildings and flora which leads to shadowing.
- Users located inside different buildings leading to multipath fading. Users could also be moving inside the rooms.
- Average inter-site distance of 350 meters.
- Roof-top mounted BS nodes with total antenna height of 20-25 meters.

All the BS and UE nodes are connected to a computing cluster housed in the Institute Computer Center (CC) over high speed GigE based WDM-PON links. The CC has two computing clusters: a 128-processor machine with 16 nodes and a supercluster with 2048 cores. These clusters can be

used to run Access network SDR implementations in a highly parallel mode.

Each BS and UE node has a multi-DSP FPGA based hardware unit for Baseband (BB) and RF processing. The block diagram of the hardware unit is shown in Figure-2. As shown in the figure, each unit will have two transceiver chains to enable 2x2 MIMO capability. DSPs and FPGA will provide sufficient processing power for embedded PHY layer processing of a 2x2 20 MHz MIMO system (detailed description of the BB processing unit is provided in the next section). Since it is desired to have 4-antenna MIMO capability for the BS node, two such BB & RF units will be required for BS node. A single unit will be required for 2-antenna UE node.

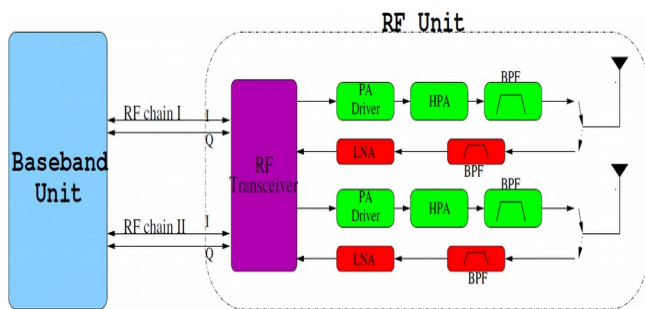

Fig.2. Block-diagram of the Baseband and RF unit

Figure-2 also shows the different sub-systems of the RF unit. RF transceiver can operate in quad-bands and has a transmission bandwidth of 20 MHz. It is designed for MIMO applications with each device supporting two transceiver chains in TDD mode. Additionally low-power PA (PA driver, with a maximum linear output power of 250 mW), high-power PA (with maximum linear output power of 5W), switch and LNA are also provided. All the nodes use GPS for timing synchronisation, although network-based approaches such as IEEE 1588v2 could also provide sufficient accuracy.

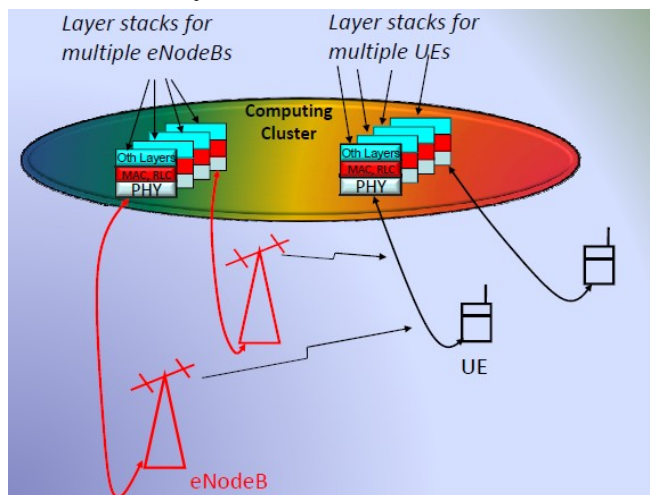

Fig.3. Flow-diagram for the centralized processing

As mentioned before, each node has embedded processing capabilities in the form of DSPs and FPGA. The CC at the back-end also has powerful parallel computing clusters. This will enable the processing of data in either centralized or distributed fashion as discussed below.

In the case of centralized processing, all the protocols of PHY, MAC as well as other layers will be run on the cluster for both BSs and UEs. The data flow-diagram for centralized processing is shown in Figure-3. This architecture is similar to the cloud radio-access-network proposed in [19] where processing for BSs is done centrally. In the testbed, processing for both BSs and UEs is done centrally and the nodes act as dumb remote radio heads (RRH) which will perform digital-to-analog/analog-to-digital conversion along with RF up/down-conversion for the transceiver chain. In this case, digitized samples of the signal transmitted/received on air will be communicated to/from RRHs as time-stamped Ethernet packets. High-resolution digitized samples will determine the bandwidth of the Ethernet link connecting the cluster and the RRHs. This testbed has been designed for 20 MHz and will currently operate in TDD mode. The DACs and ADCs used in the RRH are 12-bit devices. In the LTE realization, a sampling clock of 30.72 MHz is used for 20 MHz bandwidth. The data-rate required per antenna is thus

$$= \text{Sampling rate} \times \text{DAC/ADC resolution} \times 2$$

$$= 30.72 \times 12 \times 2 = 737.28 \text{ Mbps}$$

Two DACs and ADCs are required for complex baseband signal.

PHY layer processing is computationally intensive and has traditionally been done in an embedded fashion using DSPs and FPGAs. The parallel architecture of the computing cluster will have to be effectively harnessed to enable the PHY processing in (near) real-time. Not much information is readily available on the processing power requirement for the LTE PHY layer when it is run on such a parallel processing platform. This testbed also has a provision for embedded processing of PHY layer in distributed fashion to obviate a situation where PHY layer processing may potentially impede the real-time operations of the testbed. In the distributed processing mode, MAC and rest of the layers alone will run on the cluster. PHY layer processing will be done in distributed fashion by using the embedded processing power available in the nodes. Flow-diagram for the distributed processing is shown in Figure-4.

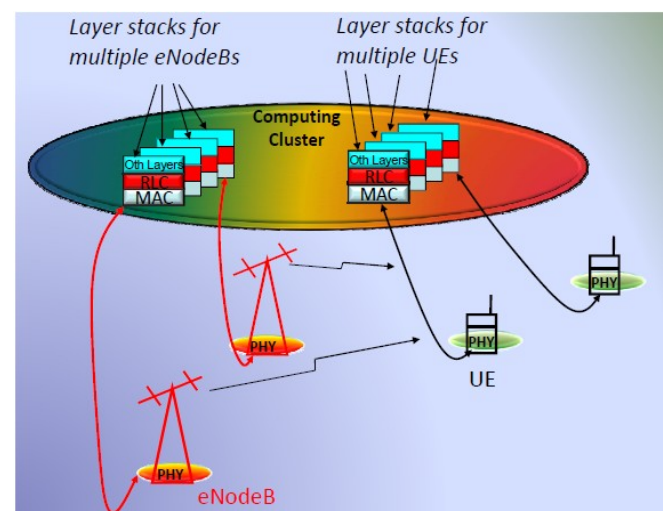

Fig.4. Flow-diagram for the distributed processing

In LTE networks, BS MAC makes the scheduling decisions for different users considering their channel conditions. In both centralized and distributed modes, MAC layer data of all BSs and UEs will be available in the CC. This will allow the study of various BS co-operation schemes without the limitation of bandwidth constraints imposed by backhaul X2 links [20]. This testbed could also be used for standalone evaluation of PHY algorithms in offline mode. In this case, similar to the Hydra testbed [10], transmit and receive data processing could be done offline in the cluster.

3 HARDWARE ARCHITECTURE OF THE BASEBAND UNIT

In this section, we provide a detailed description of the hardware architecture of the BB unit. As discussed before, each node has separate BB and RF subsections. Figure-5 provides a block diagram of the BB unit of the node. Each BB unit has two transceiver chains. There are four floating-point DSPs and a FPGA to take care of the processing requirements of the two transceiver chains. Each DSP can operate at 600 MHz and is connected to other DSPs in daisy-chain fashion using multi-Gigabit-per-second point-to-point interface. Each DSP is connected to the FPGA using the same point-to-point interface. A shared 64-bit parallel bus is also used to inter-connect DSPs and the FPGA. The bus provides data throughput of up-to 4 Gbps and provides a second path for inter-device communications along with the point-to-point interface.

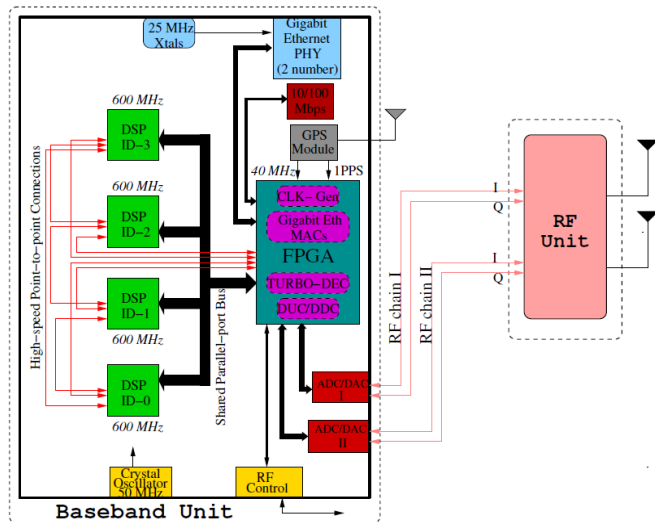

Fig.5. Block diagram of Baseband unit

Four DACs and ADCs are required to support 2x2 MIMO capability. The Mixed Signal Front End IC has two DACs and two ADCs integrated on a single chip. Two of these devices are used. Analog in-phase and quadrature signals from/to the BB section are sent to/from the RF front-end for up-conversion/down-conversion. Data-rate close to 1 Gbps is required per antenna chain for the link between cluster and RRH in the centralized mode. Each board will therefore have two 2 GigE ports. A picture of the BB platform with the labeled subsections is shown in Figure-6.

The DSP-FPGA combination also provides a convenient framework to optimise the software/hardware partitioning of the algorithms. FPGAs are used to perform the time-critical but repetitive computationally intensive tasks. LTE specifies Convolutional Turbo Coder (CTC) for forward error correction. CTC decoding is computationally intensive and needs dedicated hardware. This task for example, could be off-loaded to the FPGA. The FPGA is also used to handle the Ethernet packets, for generating the frame definitions and to implement the glue-logic for interfacing the peripherals with the DSPs.

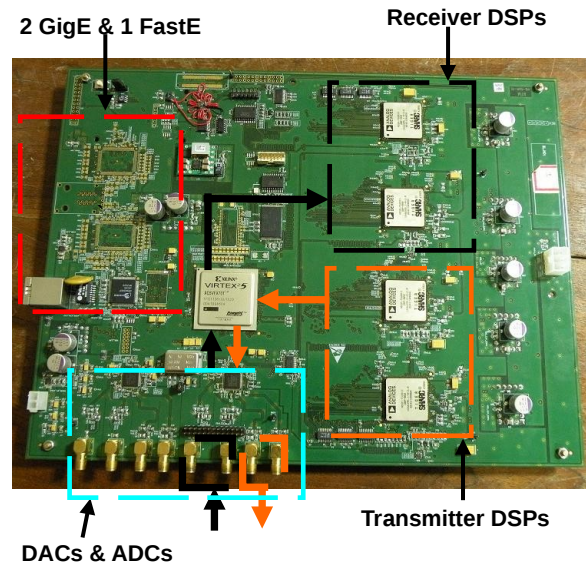

Fig.6. Picture of the prototype Baseband section

4 TECHNICAL SPECIFICATIONS OF THE ACCESS-NETWORK TESTBED

This section tabulates the key technical specifications of the testbed.

Table.1. Access-network testbed technical specifications

Parameters	Value
Transmission bandwidth	20 MHz
BS transmit power	5 W
UE transmit power	250 mW
BS antenna radiation pattern	Sector (90° beamwidth)
MS antenna radiation pattern	Omni
BS antenna configuration	4x4
UE antenna configuration	2x2
Antenna polarization	Cross
DAC/ ADC resolution	12 bits

5 END-TO-END TEST-BED

The overall testbed which also includes the Access Network described above has an equally versatile Service Layer portion implemented at University of Surrey. The

Access and the Service networks are connected through the core network of the future – Evolved Packet Core defined by 3GPP – which enables the convergence of various access technologies including LTE and LTE-A. This will enable the delivery of IP services over a wide range of wireless devices. Figure-7 below provides a high level integrated view of the Access, Core and Service delivery testbed across India and UK.

5.1 MOBILE CORE NETWORK

The Access Test bed at IITM will be connected to the Service Network at UniS through an All-IP Mobile Core Network. The Mobile Core is based on the Evolved Packet Core architecture defined by 3GPP. This new packet core architecture is simple and at the same time supports high data rates and lower latencies as required of a 4G network.

The key nodes in the Mobile Core are given below:

- **Mobility Management Entity (MME)**—The MME in this setup takes care of the control plane functions, such as authentication and session management functions.
- **Serving Gateway (SGW)**—The SGW is the user plane entity which forwards and routes packets to and from the BS in the IITM Access Network, from/to the Packet Data Network Gateway.
- **Packet Data Network Gateway (PGW)** — The PGW interfaces Mobile Core to the Service Network. The IMS and non-IMS nodes in the Service networks will be connected to the PGW. The PGW is responsible for IP address allocation. Wherever applicable, it will also do the policy enforcement.

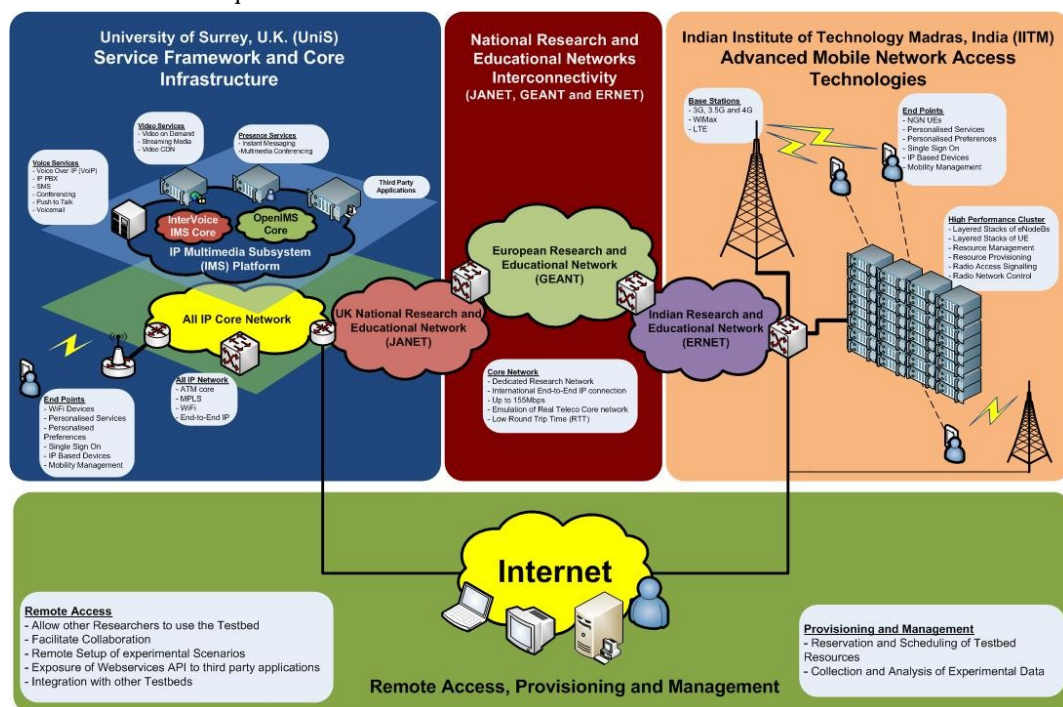

Fig.7. High level integrated view of Access, Core and Service delivery testbed

5.2 SERVICE DELIVERY PLATFORM

The service delivery platform deployed at the University of Surrey provides the ability to replicate a wide range of services deployed in real mobile operator networks. The core service delivery infrastructure is based on the IP Multimedia Subsystem to allow for better management of services, Quality of Service (QoS) management and the integration of basic services such as voice, video and data enabled services.

The service delivery platform at the University of Surrey allows for end-to-end IP connectivity tests to be carried out in real mobile environments. This enables researchers to carry out early trials and also evaluate the performance of the applications within LTE and LTE-A environments before they are deployed in production environments. Most importantly, researchers will also be able to study and investigate the interactions of various services over new

mobility schemes in the EPC such as the Proxy Mobile IP and evolved GTP (eGTP), while proposing concepts to optimize and improve both the services and the mobility schemes.

6 CONCLUSIONS

We have presented an overview of the trans-national testbed built in the IITM and UniS campuses as part of the IU-ATC project, and provided a high-level description of various components of the testbed. The testbed architecture allows for the end-to-end evaluation of the new wireless algorithms, concepts and technologies in real-world conditions. This paper explains the versatility of the testbed in terms of technologies that can be deployed, architectures that can be adopted, and the scenarios that can be emulated. We believe that the testbed will provide valuable field data which can be used for improving the design of next generation wireless networks.

ACKNOWLEDGEMENTS

The IU-ATC project is funded by the Department of Science and Technology (DST), India and Engineering and Physical Sciences Research Council (EPSRC), UK. The authors would also like to acknowledge the industrial partners in the project - Sasken Communication Technologies, L&T Infotech and Tech Mahindra for bringing in the required stacks and software for BS, UE and Core-network nodes respectively. This enables us to demonstrate the end-to-end IP applications on the testbed.

REFERENCES

- [1] Daniel J. Costello et al, 1998, "Applications of Error-Control Coding", Invited paper, *IEEE Transactions On Information Theory*, Vol. 44, No. 6, pp. 2531-2560.
- [2] David Tse and Pramod Viswanath, 2007, "*Fundamentals of Wireless Communications*" First Edition, Cambridge University Press.
- [3] Siavash M. Alamouti, 1998, "A Simple Transmit Diversity Technique for Wireless Communications", *IEEE Journal on Select Areas of Communications*, Vol. 16, No. 8, pp. 1451-1458.
- [4] I. Emre Telatar, Nov/Dec 1999, "Capacity of Multi-antenna Gaussian Channels", *European Transactions on Telecommunications*, Vol. 10, No. 6, pp. 585-595.
- [5] Vinoth Nagarajan, Bhaskar Ramamurthi, 2010, "Distributed Cooperative Precoder Selection for Interference Alignment", *IEEE Transactions on Vehicular Technology*, Vol. 59, No. 9, pp 4369-4378.
- [6] Mai Vu and Arogyaswami Paulraj, 2007, "MIMO Wireless Linear Precoding", *IEEE Signal Processing Magazine*, Vol. 24, Issue. 5, pp 86-105.
- [7] R. Zhang, K. Giridhar, and L. Hanzo, "Distributed downlink multi-cell processing requiring reduced-rate back-haul data exchange", accepted for presentation at *IEEE WCNC-2011*.
- [8] K. Naga Sekhar, et. al, 2011, "Performance Evaluation of Open Loop Multi-User MIMO Systems," *National Conference of Communications (NCC-2011)*, pp. 276-280.
- [9] Details available online at: http://www.cewit.org.in/index.php?option=com_content&task=view&id=96&Itemid=155. Accessed 17 March 2011.
- [10] K. Mandke, et. al, "Early Results on Hydra: A Flexible MAC/PHY Multihop Testbed, 2007" *Vehicular Technology Conference, 2007. VTC2007 Spring*, IEEE 65th, pp. 1896-1900.
- [11] M. Ettus, "Ettus Research, LLC," Online information on USRP board). <http://www.ettus.com>.
- [12] T. Haustein, A. Forck, H. Gabler, V. Jungnickel, and S. Schiffermuller, 2006 "Real-Time Signal Processing for Multiantenna Systems: Algorithms, Optimization, and Implementation on an Experimental Test-Bed," *EURASIP Journal on Applied Signal Processing*, Vol. 2006, Article ID 27573, pp.1-21.
- [13] D. Borkowski, et. al, "SABA: A Testbed for a Real-Time MIMO System, 2006, " *EURASIP Journal on Applied Signal Processing*, Vol. 2006, Article ID 56061, pp. 143-143.
- [14] W. Xiang, et. al, 2006 "A High-Speed Four-Transmitter Four-Receiver MIMO OFDM Testbed: Experimental Results and Analyses," *EURASIP Journal on Applied Signal Processing*, Vol. 2006, Article ID 45401, pp. 1-10.
- [15] Valeria D'Amico et. al, 2010, "ARTIST4G: A Way Forward to the Interference Problem in future Mobile Networks", *Future Networks and Mobile Summit*, pp 1-8.
- [16] E. Aschbacher, S. Caban, C. Mehlhufner, G. Maier, and M. Rupp, 2004, "Design of a Flexible and Scalable 4x4 MIMO Testbed," *Proceedings of 11th IEEE Digital Signal Processing Workshop (DSP04)*, pp. 178-181.
- [17] Details available online at: www.nkn.in. Accessed 17 March 2011.
- [18] Details available online at: www.geant2.net. Accessed 17 March 2011.
- [19] Sheng Liu and Jianjun Wu, 2011, "A 25 Gb/s/(km²) Urban Wireless Network Beyond IMT-Advanced", *IEEE Communications Magazine*, Volume: 49, Issue: 2, pp 122-129.
- [20] Erik Dahlman et. al, 2008, "*3G Evolution HSPA and LTE for Mobile Broadband*" – Second Edition, Elsevier, New york.