

## **PULSATING HEAT PIPES: PROGRESS AND PROSPECTS**

**Manfred Groll & Sameer Khandekar**

*Institut für Kernenergetik und Energiesysteme (IKE), Universität Stuttgart, Stuttgart, Germany*

Keywords: Pulsating heat pipes, Parametric influences, Slug-annular flow transition

### **ABSTRACT**

Research activities in the area of pulsating heat pipes have steadily increased after their introduction in the early nineties of the last century. These apparently simple looking cooling devices have offered considerable challenges in phenomenological and theoretical understanding. Complete design rules and optimization are yet to follow. This paper highlights major progress and milestones achieved in this direction. A comprehensive review of design rules available so far and thermal performance influence parameters is presented. With the progress achieved so far, the prospects for pulsating heat pipes seem very promising.

### **1 INTRODUCTION**

Miniaturization is in vogue today and this euphoria has especially gripped the electronics and allied industries. Market expectations towards higher functionality at reduced package sizes have led to denser electronics and increased power. Total dissipated power is not the only problem; heat flux is complimentary to it. The solution lies in development of new materials, novel cooling strategies or devices and a paradigm shift in the cooling technology concepts and modes of implementation. In line with these developmental trends are the meandering tube Pulsating Heat Pipes (PHPs), a concept proposed by Akachi [1, 2, 3] that seems to meet all the present day cooling requirements. PHPs are highly attractive heat transfer elements, which due to their simple design, cost effectiveness and excellent thermal performance may find wide applications. Since their invention in the early nineties, so far they have found market niches in power/micro electronics equipment cooling. These heat pipes are able to overcome some limitations of conventional heat pipes. (e.g., the capillary and entrainment limits). Although grouped as a subclass of the overall family of heat pipes, the complexity of thermo-hydraulic coupling is distinctly unique. PHPs are essentially non-equilibrium heat transfer devices. The performance success primarily depends on the continuous sustenance of these non-equilibrium conditions. The subtle nuances of this conceptually simple device are considerably intriguing for theoretical and experimental studies alike owing to the singular thermofluidic behavior.

The basic structure of a typical pulsating heat pipe consists of meandering capillary tubes having no internal wick structure (Figure 1a). It can be designed in at least three ways (i) open loop system, (ii) closed loop system and (iii) closed loop pulsating heat pipe with additional flow control check valve(s), as shown in Figure 1b. The entire essence of thermo-mechanical physics lies in the closed (constant volume), two-phase, bubble-liquid slug system formed inside the tube bundle due to the dominance of surface tension forces. This bundle of tubes receives heat at one end and is

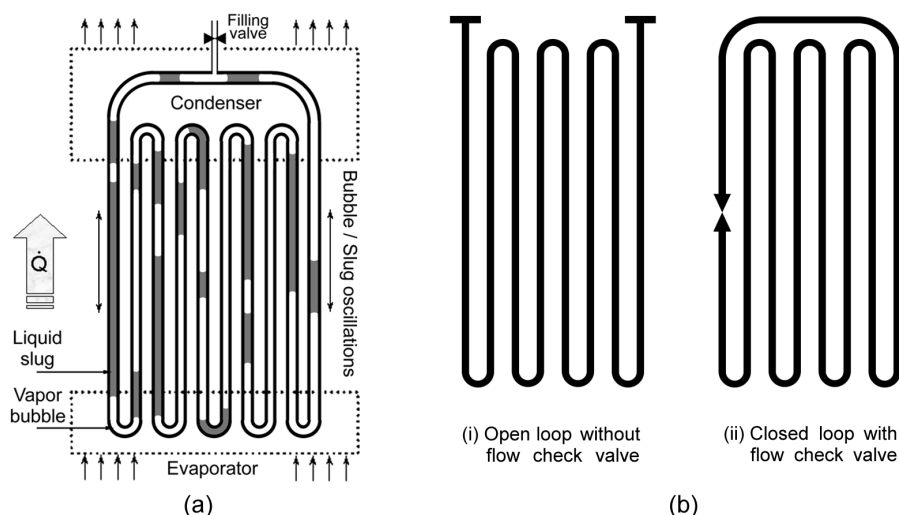

Figure 1: (a) Basic constructional details of a closed loop pulsating heat pipe, (b) Various physical configurations of a pulsating heat pipe.

cooled at the other end. Temperature gradients give rise to temporal and spatial pressure disturbances in the wake of phase change phenomena (generation and growth of bubbles in the evaporator and simultaneous collapse of bubbles in the condenser). The generating and collapsing bubbles act as pumping elements transporting the entrapped liquid slugs in a complex oscillating-translating-vibratory fashion resulting in efficient heat transfer.

## 2 HISTORICAL DEVELOPMENT

'Drinking or Dunking Duck', the popular toy which has amused generations of children may be the 'Neanderthal', symbolizing a vital link in the evolutionary chain of modern pulsating heat pipes. The details of the toy are shown in Figure 2. The kernel of two-phase physics and associated thermo-mechanical interactions are inherent in the design. This toy is a classic example of a closed passive two-phase system which generates 'perpetual mechanical motion' through evaporative heat transfer (volumetric filling ratio of the vapor/ liquid remains constant throughout the operation).

While it may be difficult to trace the origin of the 'drinking duck', a more formal presentation of an analogous concept is contained in a patent filed in the former USSR by Smyrnov et al. [4]. The conceptual details are shown in Figure 3, consisting of two container bulbs, evaporator 'E' and condenser 'C', and a joining tube 'T'. At the beginning the evaporator end and the connecting tube are completely filled with the working fluid while the condenser end is partially filled, the rest being a passive, non-participating gas, as shown. Heating at the evaporator end, expands the working fluid and pushes it into the condenser bulb. Further heating generates vapor in the evaporator bulb and pushes the liquid further into the condenser, thereby compressing the trapped passive gas. Simultaneously, the vapor also starts being condensed at the inner surface of the connecting tube thereby reducing the pressure locally. In addition, the passive gas is compressed substantially by this stage. Depending on the instantaneous prevalent pressure (mis-)distribution in various sub-sections of the device, the potential energy stored in the passive gas will, at some stage, push the liquid back to the evaporator bulb. The cycle thus repeats by thermo-mechanical sustained non-equilibrium generated by closed passive two-phase, two-component system trapped in isochoric geometry.

Although the fundamental concept of 'Pulsating Heat Pipe', as defined in this paper, is inherent in the patent by Smyrnov et al., the optimal exploitation from an engineering point of view has been achieved in the design as proposed by Akachi et al. [3, 5]. Thus, the first predecessor of the family of modern PHPs appeared in 1990s. In the background of this information, we now review the present understanding of operating mechanisms, influence parameters, flow physics and overall progress and prospects of closed loop valve-less pulsating heat pipes.

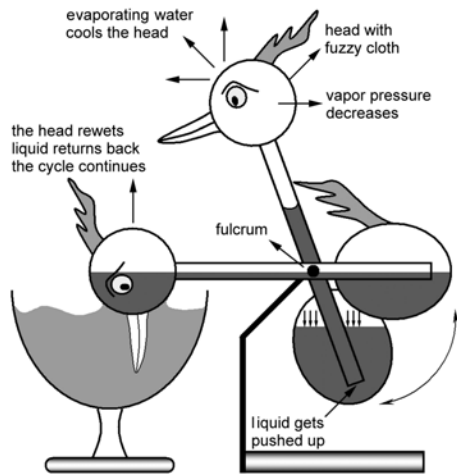

Figure 2: The drinking duck operation.

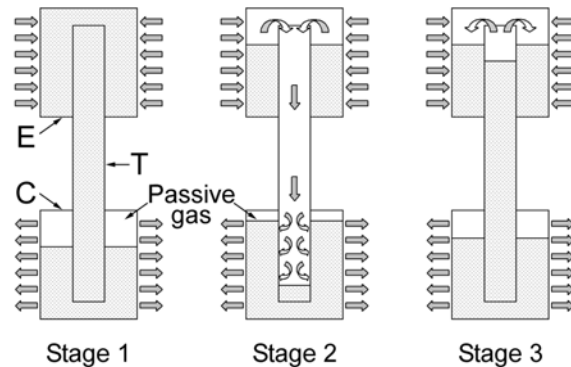

Figure 3: Design as patented by Smyrnov et al. [4].

### 3 CRITICAL DESIGN ISSUES

In the discussion that follows closed loop pulsating heat pipes without check valves will be considered. A brief look at the complex operating mechanism of the device reveals that there is multitude of influence parameters affecting the thermal performance. It is rare to find a combination of such events and mechanisms, like bubble nucleation and collapse, bubble agglomeration and pumping action, pressure/temperature perturbations, flow regime changes, dynamic instabilities, metastable non-equilibrium conditions, flooding or bridging etc., all together contributing towards the thermal performance of a device. The objective function is certainly complex and non-linear in nature and so there are various critical design issues to be considered. Listed here are few such questions, which are to be fully addressed before practical designing.

- a. Are pulsating heat-pipes real 'heat pipes' in the conventional sense?
- b. What is the effect of two-phase flow patterns on the thermal performance?
- c. How is the thermal performance related to the fill ratio (liquid volume/total internal volume)?
- d. What is the effect of diameter on the thermal performance and on the very definition of pulsating heat pipes?
- e. What is the effect of condenser capacity on the device performance? Will increasing condenser capacity always increase the thermal performance?
- f. Which fluids are best suited for pulsating heat pipes?
- g. What is the effect of number of turns on the performance?
- h. How does gravity come into picture?

While the above stated list of design issues is by no means complete, understanding of these issues is vital for further development. Many of the above aspects have been addressed in the literature available so far but a complete comprehensive understanding, leading to quantitative predictions, is still in sophomore stages. In the next sections, a brief overview on some of the above raised issues is done.

#### 3.1 Thermo-fluidic coupling and heat transfer characteristics

In an optimally operating conventional wicked heat pipe, the liquid flows inside the circumferential wick structure while the vapor flows in the central core. Thus, a countercurrent annular flow exists. Latent heat is the primary mode of heat transfer and sensible heat transfer, in any, may be neglected. This is in contrast to 'pulsating heat pipes'.

It is obvious from the construction of PHPs that capillary slug flow exists due to the dominance of surface tension forces as shown in Figure 4a. Under such flow conditions, the flow invariably changes direction after a finite time depending on heat flux, Eötvös number and fill charge [6, 7].

If this flow pattern remains throughout the operation for given boundary conditions then the condenser section experiences saturated vapor and liquid slugs simultaneously (assuming no metastable effects). Since the mass of vapor bubbles is negligible as compared to liquid mass, the latent heat portion from the vapor bubble is an order of magnitude smaller as compared to the equivalent sensible heat transfer from the liquid slug during the simultaneous cooling of the two-phase mixture. This has indeed been observed by studies so far that the sensible heat transfer is the major contributor in the overall heat exchange [8, 9, 10]. Thus, the term ‘pulsating heat pipe’ seems apparently to be a misnomer. An interconnected array of capillary bubble pumps better describes the device.

Further studies have strongly indicated that the above written facts are only partially correct and depend on the imposed geometric and thermal boundary conditions. Transition to annular flow has been observed at relatively higher heat fluxes, even at capillary tube dimensions of 2.0 mm (which satisfies the criterion for critical diameter, i.e.  $Bo \approx 2$ ) for fluids like water, ethanol and R-123 [11]. Under such operating conditions, lower thermal resistance has been observed as dominance of sensible heat transfer gives way to latent heat transfer. In addition, rather than bulk pulsating motion and change of flow direction as observed at lower heat fluxes (when predominantly slug flow exists), the flow takes up a fixed direction and alternating tubes are hot and cold as shown in Figure 4b. The direction, which the flow takes, is arbitrary for a given experimental run but once it is established, it remains fixed and does not turn around. If the heat flux is now decreased slowly, reverse transition to slug flow commences and then the flow again starts pulsating with a simultaneous lowering of performance. This also suggests that in the limiting conditions PHPs may be made analogous to conventional heat pipes as far as the latent heat transfer is concerned. Although in such a limiting condition a PHP may be better named as an interconnected array of thermosyphons. Then again, the term ‘pulsating’ is questionable.

The slug-annular transition depends not only on the heat input but also on the geometrical constructional features. The length of tube sections in the condenser and evaporator will determine the flux at which heat is being rejected and fed in. The flow Weber number, entrainment due to Helmholtz type instabilities and subsequent ‘bridging’/ ‘flooding’ phenomena and other forms of dynamic instabilities are the limiting factors of the slug-annular transition. The process is schematically shown in Figure 4b. Metastable conditions are also expected in real systems since heat and mass transfer processes have finite inertia. Even when the flow pattern is predominantly slug flow, various bubble agglomeration and breaking patterns have been observed [12].

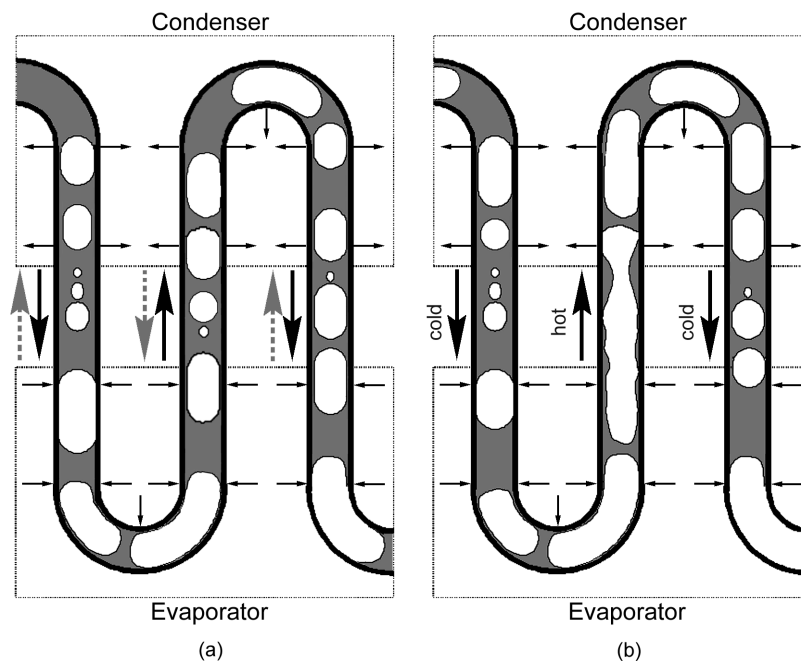

Figure 4: (a) Slug flow regime in pulsating heat pipes; the flow changes direction with a time period of few seconds, (b) once transition to annular flow takes place, the bulk flow direction tends to stabilize and tubes become alternately hot and cold.

### 3.2 Thermodynamic considerations

There exist pressure differentials in the system caused by both, expanding bubbles in the evaporator and contracting bubbles in the cooler. While the system as a whole is isochoric having no associated PdV work, local control volumes in the evaporator and condenser are essentially involved with work interactions with adjoining fluid particles. Heat addition along with ‘positive pumping’ by the expanding bubbles is taking place in the evaporator. In the condenser, the bubbles collapse giving up the heat and in turn do ‘negative pumping’ work on the adjoining fluid particles.

When bulk movement of the fluid is taking place, in general, the quality of two-phase mixture coming out of the condenser is certainly inferior to that existing at the evaporator outlet. Simultaneously, the fluid pressure is also lower at the condenser outlet. So, considering the P-h diagram for one loop of a pulsating heat pipe, as shown in Figure 5, although exact positions are not known, relative locations of the state of fluid at condenser and evaporator outlet are determinable (it is emphasized that these are strictly instantaneous positions). In the adiabatic fluid transport sections, an isenthalpic pressure drop seems to be a satisfactory assumption. By applying this, the condenser inlet and evaporator inlet points are also known. What happens inside the evaporator and condenser remains to be fixed to complete the qualitative description of the possible instantaneous thermodynamic cycle of the loop. The simultaneous heating up and pressurizing of the fluid in the evaporator is a rather complex process. For analysis it may be conveniently subdivided into two thermodynamic processes, constant pressure heat addition and isentropic pumping up by the bubbles. Similarly, in the condenser, constant pressure condensation is coupled with negative isentropic work. How these complex processes are linked so as to realistically complete the processes A-B and D-E (dashed lines) in Figure 5 is yet to be determined [11].

If we compare the PHP system with a standard vapor compression refrigeration cycle (or a heat pump), we notice that the latter has a compressor and an expansion valve to isolate the high and low pressure sides of the system. In contrast, a PHP is a continuous tube in which, although a pressure differential exists, there is no physical isolating device for the high and low pressure sides. This isolation is, in effect, carried out by the bubble menisci which are dynamically moving.

The fact that the overall system volume is fixed, provides another interesting thermodynamic aspect. Operating the device at any temperature (within reasonable limits and avoiding near critical operation), necessarily does not alter the volumetric fill ratio; only the vapor density varies with the operating temperature. So, if  $T_e$  and  $T_c$  are fixed (thereby fixing the respective working pressures), a given system with a fixed volumetric ratio will have a fixed corresponding mass quality at the two respective temperatures. Figure 6 plots the volumetric ratio of vapor against the mass quality of vapor for ethanol at 25°C and 100°C. It is clearly seen that the overall mass quality of the vapor phase is extremely low for the range of applicable volumetric ratios of vapor. This also explains the minuscule role of latent heat in the overall heat transfer, as mentioned earlier.

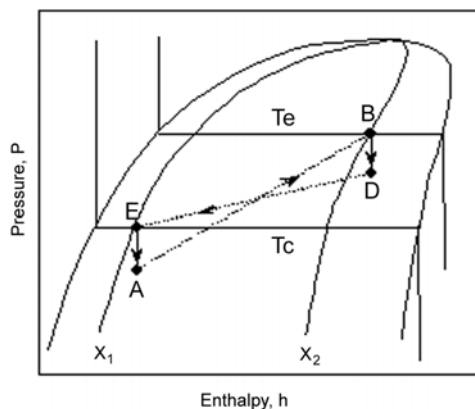

Figure 5: Instantaneous thermodynamic cycle of one loop of pulsating heat pipe; A-Evaporator inlet, B-Evaporator outlet, D-Condenser inlet, E-Condenser outlet).

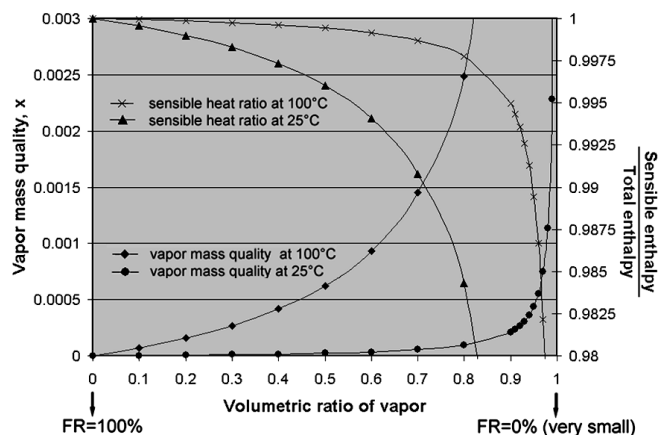

Figure 6: Volumetric ratio of vapor to mass quality of vapor in the operating range of a pulsating heat pipe.

### 3.3 *Effect of diameter*

The formation of distinct slugs is attributed to the balance of gravity and surface tension forces. This balance leads to the definition of Bond (Bo) or alternatively the Eötvös number (Eö) ( $Bo = D\sqrt{g(\rho_l - \rho_v)}/\sigma = \sqrt{Eö}$ ). In general,  $Bo \approx 2$  is the limit of surface tension predominance over gravity. Further, two important conclusions can be drawn regarding the diameter of PHPs:

- For a specified heat throughput and maximum allowable evaporator temperature and all other geometry remaining fixed, decreasing the diameter from an optimum value will decrease the performance. This happens because the driving frictional pressure head increases. Further, the total fluid inventory inside the PHP reduces bringing down the sensible portion of heat transfer. The smaller the diameter, the more difficult it is to develop annular flow, which, as explained later is desirable. Diameters above an optimum value lead to stratification of phases and so a PHP loses its fundamental character. It no longer remains a PHP but instead becomes an interconnected array of two-phase thermosyphons. If the specified heat throughput can generate sufficient wall superheat creating favorable conditions for nucleate pool boiling then this interconnected array of thermosyphons may be thermally a better option, at least for vertical operation. It is also important to note that the optimum diameter mentioned above is based on the premise that all other influence parameters (e.g. fill ratio) are optimally specified.
- In general, the maximum performance will monotonously increase with increasing diameter. After a critical diameter, the device will no longer be a PHP, as stated earlier.

### 3.4 *Effect of fill charge*

A given PHP has two operational extremities with respect to the filling charge, i.e. 0% filled (or an empty device) and 100% filled. At 0% fill ratio (bare tubes and no working fluid), it is a pure conduction mode heat transfer device and obviously has a very high thermal resistance. A 100% fully filled device is identical in operation to single-phase natural convection thermosyphon. Since there exist no bubbles in the tube, a ‘pulsating’ effect is obviously nonexistent but substantial heat transfer takes place due to liquid circulation by thermally induced buoyancy. It is interesting to note that a 100% filled device may perform better than a partially filled device as seen in Figure 7 [12]. In between these two extremities there exist three distinct sub-regions [13]:

- Nearly 100% fill ratio: In this mode there are only very few bubbles present rest being liquid phase. These bubbles are not sufficient to generate the required pumping action/perturbations resulting in a small overall degree of freedom. The buoyancy induced liquid circulation, which was present in 100% filled case, gets hindered due to additional surface tension generated bubble friction. The few bubbles present tend to agglomerate in the upper condenser section and it becomes difficult for the bulk liquid to push them down due to buoyancy. Thus, the performance of the device is seriously hampered compared to a 100% filled PHP.
- Nearly 0% fill ratio: In this mode, there is very little liquid to form enough distinct slugs and there is a tendency towards evaporator dry-out. The operational characteristics are unstable. The device may, under some operating conditions, work as a two-phase thermosyphon but capillary bridging and intermittent flow characteristics render the operation unstable and ineffective.
- PHP true working range: In between about 20% to 80% fill charge the PHP operates as a true pulsating device. The exact range will differ for different working fluids, operating parameters and construction. The more bubbles (lower fill charges), the higher is the degree of freedom but simultaneously there is less liquid mass for sensible heat transfer. Less bubbles (higher fill charges) cause less perturbations and the bubble pumping action is reduced thereby lowering the performance. Thus, an optimum fill charge exists.

Also it is interesting to note that since the whole PHP system is isochoric, any bubble disappearance or collapse must be associated by simultaneous generation of some other bubble somewhere in the system, either by flashing or by drawing heat from the environment. This necessarily means that the time average volumetric fill ratio of a PHP, operating in a quasi steady state mode, remains constant. The probability of annular flow becomes high with a combination of high Eötvös number, high heat flux and comparatively low fill ratio ( $\approx 50\%$  or lower). It is increasingly difficult to have annular flow anywhere in the system as the fill ratio is increased above a particular value. This also partly explains the reduction in performance at higher fill ratios.

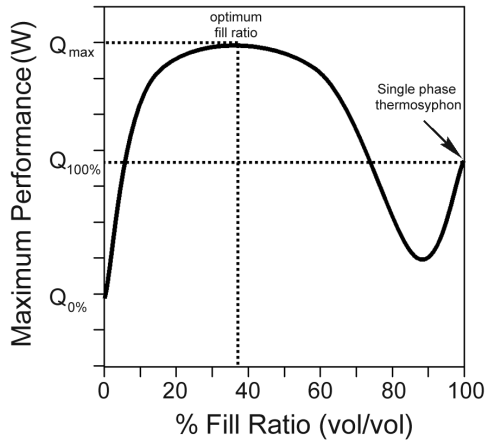

Figure 7: Effect of fill ratio for a closed loop pulsating heat pipe in vertical orientation, heater down position (maximum performance for a specified maximum average evaporator temperature).

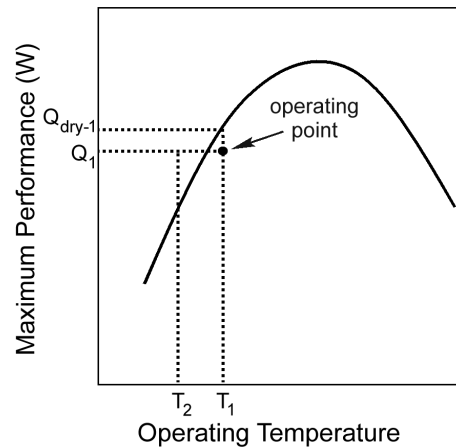

Figure 8: The effect of condenser capacity on a conventional heat pipe; dryout occurs when the operating temperature shifts from  $T_1$  to  $T_2$ .

### 3.5 Effect of condenser capacity

A typical performance characteristic of a conventional heat pipe is shown in Figure 8. The heat pipe is assumed to be operating at an adiabatic temperature of  $T_1$  with heat input of  $Q_1$ , very close to the dryout power  $Q_{dry-1}$  corresponding to the operating temperature. If, under such operating conditions the condenser capacity is increased, by either lowering the coolant temperature or increasing the coolant mass flow, there is a risk of a dryout to occur. This will happen since the operating temperature drops to  $T_2$  for which the heat input  $Q_1$  is too high. Thus, increasing the condenser capacity need not necessarily improve the heat transfer for conventional heat pipes.

Although there is no well defined adiabatic operating temperature for pulsating heat pipes, a similar trend regarding the effect of condenser capacity may be observed. Increasing the condenser capacity affects not only the thermophysical properties of the working fluid but as a side effect alters the slug-annular flow pattern transitions, thereby altering the final performance. This aspect has to be addressed while practical designing.

### 3.6 Effect of working fluid

The experience gained so far by earlier studies suggests that the working fluid employed for pulsating heat pipes should have the following properties:

- High value of  $(dP/dT)_{sat}$ : ensuring that a small change in evaporator temperature generates a large change in corresponding  $P_{sat}$  inside the generated bubble which aids in the bubble pumping action of the device. The same is true in reverse manner in the condenser.
- Low dynamic viscosity: which generates lower shear stress.
- Low latent heat: should be desirable, aiding quick bubble generation and collapse, given the fact that sensible heat is the predominant heat transfer mode.
- High specific heat: is desirable complimenting the low latent heat requirement; although there are no specific studies which explicitly suggest the effect of specific heat of the liquid on the thermal performance. It is to be noted that if a flow regime change from slug to annular takes place, the respective roles of latent and sensible heat transport mechanism may considerably change, as explained earlier. This aspect requires further investigation.
- Low surface tension: which, in conjunction with dynamic contact angle hysteresis may create additional pressure drop.

The above noted property trends are based on the available knowledge so far and are subject to change as more studies reveal the thermo-mechanical physics. In addition, quite often instead of individual thermophysical properties, groups of properties affect complex real systems like PHPs. In the wake of flow pattern dependency of the thermal performance of PHPs, different operating regimes of the device are likely to be affected by different groups of thermophysical properties.

## 4 CONCLUSIONS

Pulsating heat pipes are complex systems which have high potential as heat transfer devices in various applications. The thermal performance objective function is multi-dimensional and embodies major multi-disciplinary physics of two-phase systems. Although a lot of information is now available on the operational characteristics of PHPs, this information is predominantly qualitative in nature. Quantitative modeling and designing rules are yet to follow.

## 5 NOMENCLATURE

g : acceleration due to gravity ( $m/s^2$ )  
 Bo : Bond number =  $D \cdot (g(\rho_l - \rho_v) / \sigma)^{0.5}$   
 D : diameter (m)  
 Eö : Eötvös number =  $(Bo)^2$   
 P : pressure (Pa)  
 Q : heat input (W)  
 T : temperature ( $^{\circ}C$ )

### Greek Symbols

$\sigma$  : surface tension (N/m)  
 $\rho$  : mass density ( $kg/m^3$ )

### Subscripts

e : evaporator  
 c : condenser  
 l : liquid  
 sat : saturation  
 v : vapor

## 6 ACKNOWLEDGEMENTS

This research work is partly supported by Deutsche Forschungsgemeinschaft (DFG) under grant GR 412/33-1.

## 7 REFERENCES

1. Akachi H., US Patent, Patent Number 4921041, 1990.
2. Akachi H., US Patent, Patent Number 5219020, 1993.
3. Akachi H., US Patent, Patent Number 5490558, 1996.
4. Smyrnov G. and Savchenkov G., former USSR Patent, Patent Number 504065, 1975.
5. Akachi, H., Polášek, F. and Štulc, P., Pulsating Heat Pipes, 5th Int. Heat Pipe Symposium, Melbourne, Australia, pp. 208-217. 1996.
6. Khandekar S., Schneider M., Schäfer P., Kulenovic R. and Groll M., Thermofluiddynamic Study of Flat Plate Closed Loop Pulsating Heat Pipes, *Microscale Thermophysical Engineering*, Taylor and Francis, ISSN 1089-3954, pp. 303-318, Vol. 6, No. 4, 2002.
7. Tong B., Wong T. and Ooi K., Closed-Loop Pulsating Heat Pipe, *Applied Thermal Engineering*, Elsevier Science, ISSN 1359-4311, Vol. 21, pp. 1845-1862, 2001.
8. Groll M. and Khandekar S., Pulsating Heat Pipes: A Challenge and Still Unsolved Problem in Heat Pipe Science, *Archives of Thermodynamics*, Begell House, ISSN 1231-0956, Vol. 23, No. 4, pp. 17-28. 2002.
9. Nishio S., Nagata S., Baba S. and Shirakashi R., Thermal Performance of SEMOS Heat Pipes, *Proc. 12th Int. Heat Transfer Conf.*, ISBN 2-84299-307-1, Grenoble, France, Vol. 4, pp. 477-482, 2002.
10. Shafii M., Faghri A. and Zhang Y. Thermal Modeling of Unlooped and Looped Pulsating Heat Pipes, *ASME Journal of Heat Transfer*, Vol. 123, pp.1159-1172, 2001.
11. Khandekar S. and Groll M., An Insight into Thermo-Hydraulic Coupling in Pulsating Heat Pipes, *Int. J. of Thermal Sciences (Rev. Gén. Therm.)*, Elsevier Science, ISSN: 1290-0729, Paper under review.
12. Khandekar S., Groll M., Charoensawan P. and Terdtoon P., Pulsating Heat Pipes: Thermo-fluidic Characteristics and Comparative Study with Single Phase Thermosyphon, *Proc. 12th Int. Heat Transfer Conf.*, ISBN 2-84299-307-1, Grenoble, France, Vol. 4, pp. 459-464, 2002.
13. Khandekar S., Dollinger N. and Groll M., Understanding Operational Regimes of Pulsating Heat Pipes: An Experimental Study, *Applied Thermal Engineering*, Elsevier Science, ISSN 1359-4311, (accepted for publication), 2003.