

RRI-GBT Multi-Band Receiver and Pulsar-Emission-Cone Tomography

Avinash A Deshpande

Raman Research Institute, Bangalore 560080, India desh@rri.res.in

Abstract

We report the development of a self-contained multi-band dual-polarization receiver system, simultaneously sampling signal voltages in 10 tunable bands across 100-1500 MHz wide spectral span. The primary motivation is to use this receiver with a single large aperture to enable full-Stokes tomographic probe of the pulsar emission cone, also opening attractive possibilities for other astronomical investigations. The tests and observations carried out using this system at the Green Bank Telescope (GBT), and the preliminary results from pulsar observations using GBT will be presented. **(On behalf of the RRI-GBT Multi-Band Receiver Team)**

1 Introduction and Motivation

Even after 40 years of pulsar studies, theorists and observers have not quite succeeded in relating the puzzling rich details exhibited by pulsars to the physical processes responsible for the observed radio emission. While the average pulse profile with polarization information tells us more about the viewing geometry and provides important constraints about the possible emission mechanisms, the fluctuations from pulse to pulse are seen to provide further crucial details relating to the actual physical processes in the magnetosphere. Recent studies of such fluctuations in pulsar signals suggest that plasma processes responsible for pulsar emission may be organized into a system of columns seeded by a well-defined pattern of spark discharges in the acceleration region and undergoing steady circulation around the magnetic axis [1,2]. Estimation of circulation time associated with the system of emission columns has been possible so far in only a few pulsars, and the important details determining such configurations and the pattern circulation are yet to be understood. Noting that the high frequency emission takes place close to the star, and radiations of progressively lower frequencies are emitted farther away from the star's surface (Radius to Frequency Mapping), simultaneous multi-frequency observations would be expected to sample the polar magnetosphere at various heights, providing a tomographic view of the pulsar emission cone. Such a probe at single pulse resolution would reveal much needed clues about generation of seed patterns in the acceleration zone and their evolution as manifested through radio emission from different regions of the magnetosphere.

With this primary motivation, and to enable simultaneous multi-frequency observations at high temporal and spectral resolution, a "self-contained" wide-band system for use with a single large aperture was considered (which overcomes the various difficulties and limitations inherent in the multi-frequency setup attempted so far using many telescopes simultaneously, each observing at different frequencies).

Apart from the above primary aim, the MBR system with its simultaneous multi-frequency observing capability opens new opportunities particularly in probing interstellar scattering and scintillation, spectral evolution of pulse-shape polarization and flux-density, and enables more sensitive search for fast-transient; discriminating the signals of astronomical origin from those due to radio frequency interference(RFI) decisively, and for speedy surveys in continuum and recombination lines. Although the center frequencies of various frequency bands and various other specifications of the present receiver system are chosen appropriately so as to use the large collecting area offered by the Green Bank Telescope (GBT), the design and structure of the system is generic enough to enable its use at any suitably large aperture telescope.

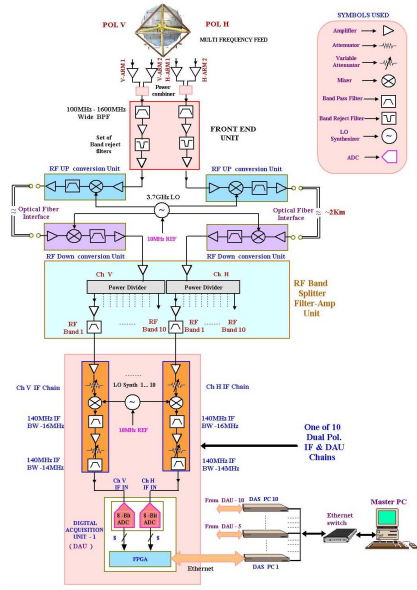

Figure 1: The overall block diagram of the receiver

2 A brief description of the MBR system

The overall block diagram of the complete receiver system (including the multi-band feed) is shown in Figure 1. The multi-feed for prime-focus of GBT is based on the configuration as in the Kildal “Eleven Feed” [3]. It consists of 10 resonant pairs of half-wave dipoles (see Figure 2) placed at $\lambda/4$ from its common (ground-plane) reflector and with pair spacing of $\lambda/2$, providing 10 well-defined spectral responses, providing also deliberate rejection at RFI-prone frequency ranges in between. The two orthogonal sets of pairs provide dual linear polarization outputs, with desired matching across respective E and H-plane beams, and with the phase center that is desirably independent of wavelength. Each of the polarization channels from the dual polarization multi-band feed is followed by a wide-band (100–1600 MHz) low-noise amplifier (LNA) to appropriately enhance the signal, followed by a set of filtering stages, defining the overall spectral range, as well as for rejection of RFI in two specific ranges. An up/down frequency conversion stages allow transmission from the receiver room to the control room of the GBT on the existing optical fiber network. After the different subbands are separated via a filterbank, the ten high-gain receiver chains cater to the 10 tunable bands, each within preselected spectral windows in the relatively RFI-free regions. Included in the chain is a conversion to common IF frequency at which the sharp band-pass filters define the 16 MHz band to be sampled by the digital receiver.

The dual polarization signals for each band are digitized using 8-bit dual-channel ADC, sampling at 33 MHz rate, and these signal are processed by FPGAs performing packetizing. The packetized data is sent to the separate computers through Gigabit Ethernet (GbE). In the second phase, a poly-phase spectrometer will be employed.

A monitoring-and-control interface in software enables control of the IF attenuation and LO frequency setting, as well as sniffing the data that is sent to a master control computer for monitoring.



Figure 2: Multi-Band Feed

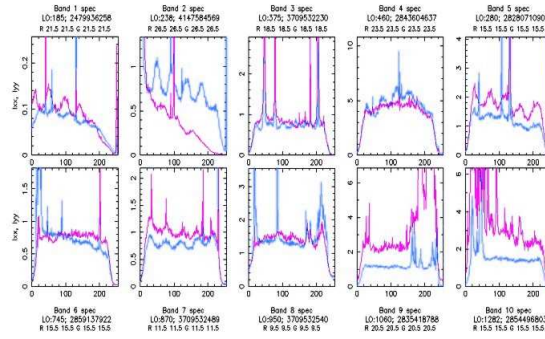

Figure 3: A sample of on-the-fly recorded Multi-band spectra

3 Observations and Results

The multi-band system outlined above was build successfully and the results of test observations with the GBT are shown below. Figure 3 shows a sample of the spectra observed simultaneously for the 10 bands, each with dual polarization. Figure 4 shows the intensity time sequence during a slew across a strong continuum source. The response width provides an estimate of the beam-width at respective frequencies. The width is seen to scale as expected with wavelength, indicating that the feed illuminates the dish similarly across the spectral range probed.

Several pulsars were observed using this system at GBT, and the data are being analyzed to probe the emission of cone at several heights. New results from these data will be discussed.

4 Contributors to the RRI-GBT Multi-Band Receiver development

From RRI: C. Vinutha, Jayantha Chennamagalam, Yogesh Maan, K. B. Raghavendra Rao, R. So-mashekar, H. A. Aswathappa, M. S. Ezhilarasi, S. Sujatha, P. Sandhya, S. Kasturi, T. S. Mamatha, Salna, Deepa, Vishakha S. Pandharpure, K. S. Srivani, Durai Chelvan, G. Sarabagopal, H. N. Nagaraja, P. A. Kamini, Shahram Amiri, Wasim Raja, Nikhil Mehta, Harshad Sahasrabudhe, Narayana, Anand, Venu, Dhamodaran, C. M. Ateequlla and other members of Radio Astronomy Lab, Mechanical Workshop, Computer Group and Gauribidanur Field Station of the Raman Research Institute, .

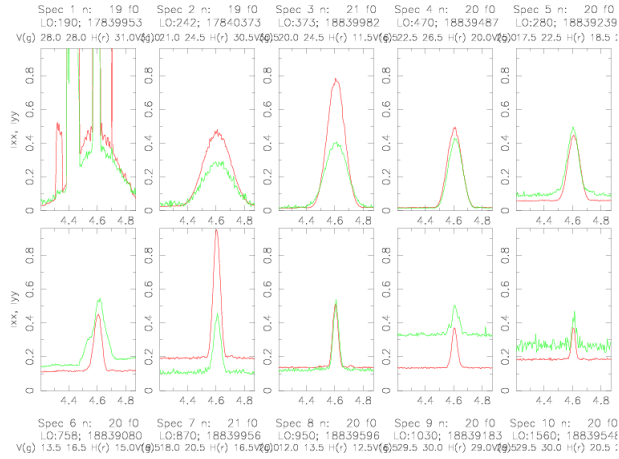

Figure 4: A slew-scan across Cas-A

From IIA: Indrajit Barve, Rajalingam, Kathiravan

From GBT-NRAO: Gary Anderson, Jonnah Bauserm, Carla Beaudet, Steve White, Marty Bloss, Karen O'Neil and others at the Green Bank Telescope, NRAO.

5 Acknowledgments

We gratefully acknowledge encouraging support from NRAO, Green Bank through out the course of this project. We also thank GMRT, NCRA Pune for support during initial tests conducted using one GMRT dish.

6 References

1. Deshpande, A. A. & Rankin, J. M., 1999, The Astrophysical Journal, Volume 524, Issue 2, pp. 1008-1013
2. Asgekar, A. & Deshpande, A. A., 2001, Monthly Notices of the Royal Astronomical Society, Volume 326 (4), pp. 1249-1254.
3. Olsson R., Kildal P. S. & Weinreb S., 1981, IEEE Trans. Ant. Prop., 54, pp. 2